

Olide-120B OWNER'S MANUAL



INSTALLER NOTES:

The programming of the Open&Close stopping points will occur after the initial hardware installation. An uninstalled unit will result in constant motor rotation. For support, please email us : tech@olideautodoor.com

SMARTER BUILDING, SMARTER LIFE

Olide Technology Co., Ltd
Manufacturer of Automatic Entry system

Contents

1. Technical Parameters.....	1
2. Components.....	2
3. Installations.....	3
3.1 Installation example.....	3
3.2 Installation of base plate.....	4
3.3 Installation of pull arm.....	5
3.4 Installation of push arm.....	6
3.5 Installation of Push arm for frameless glass door.....	8
3.6 Installation of Pull arm for frameless glass door.....	8
3.7 Installation of operation system.....	9
3.8 Installation of cover.....	9
3.9 Connection the operation system with the pull arm.....	10
3.10 Connection the operation system with the push arm.....	11
4. Electrical Connections.....	12
Control panel details.....	12
4.1 Connecting with access keypads	12
4.2 Connecting to Smart Access Keypad 270,272	13
4.3 Connections with PIR sensors	13
4.4 Connections for safety motion top scan	14
4.5 Connections for push buttons.....	14
4.6 Connections for wiring disabled push buttons.....	14
4.7 Connecting to wireless handicapped push buttons and wave to open switches.....	15
4.8 Connections for magnetic locks	15
4.9 Connections for electric locks.....	15
4.10 Connection with the touchless hand sensor switches	16
4.11 Connecting to wireless touchless sensor switch 25A.....	16
4.12 Connecting to wired touchless sensor switch 201G.....	16
4.13 Connecting to wired touchless sensor switch DL56.....	17
4.14 Connecting to wired handicap wave to open touchless buttons.....	17
4.15 Connecting to washroom switch for disbaled.....	18
4.16 Connecting to wireless hand sensor switch 201W	18
4.17 Double door synchronous settings	19
4.18 Wireless push buttons settings.....	20
4.19 Remote control settings.....	21
5. Parameters Adjustment.....	22
5.1 hand programmer instruction.....	22
5.2 adjustment steps.....	23
6. Trouble Shooting.....	24

1 Technical Parameters

Voltage:	110-220 VAC +/-10%	
Power Consumption:	50W	
Opening Time:	3-7 sec. @ 90 degrees	
Hold Open Time:	1-30 sec. Adjustable	
Max. Door Frame Depth:	450mm / 17.7"	
Door Width:	Min. 660mm / 26"	Max. 1200mm / 47.2"
Max. Opening Angle:	120 degrees	
Environment Temperature:	-20C to 50C	-4F to 122F

Protection Class:	IP12D	
Product Weight:	9Kg	19.8lbs
Dimensions:	L540 x H100 x W80mm L21.2" x W3.9" x H3.14"	

mm=Door width

kg=Door weight

 Suitable range

 Range limit

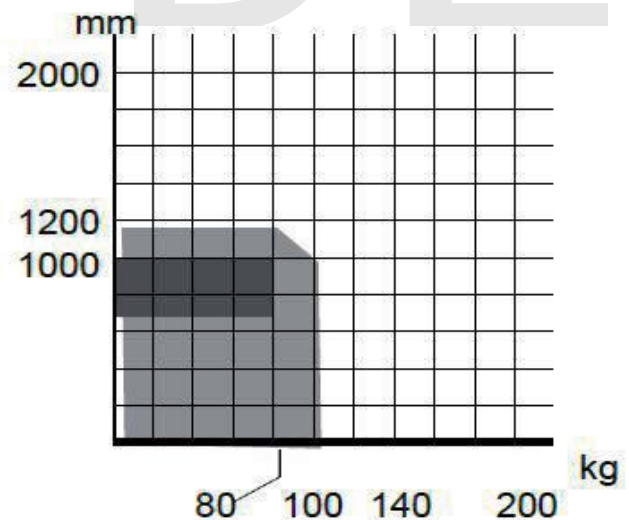

2 Component

Base Plate:

Power cable hole

Sensor cable hole

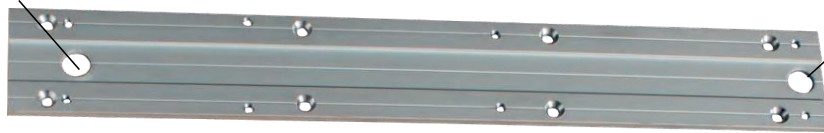

Motor Assembly:



Brushless DC motor



Strong gear system



intelligent controller



Power switch



Wiring connector

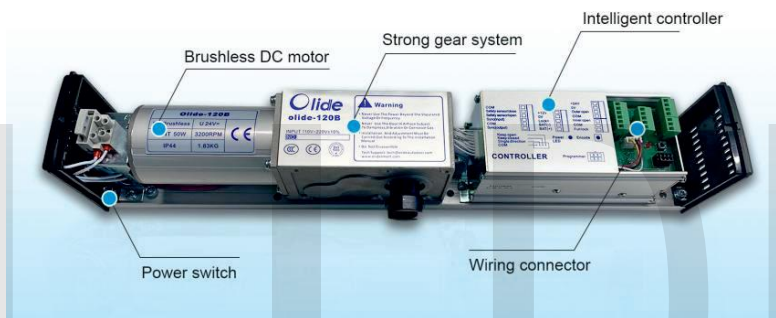

Cover Plate:



Pull Arm(Option for inswing opening)



Push Arm(Option for outswing opening)



Pull Arm(Option for frameless glass inswing opening)



Push arm glass clamp

3 Installation

3.1 Installation example

Pull Arm

The door opens to the inside toward the unit using the pull arm assembly.

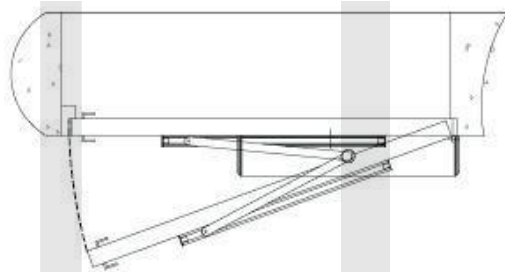
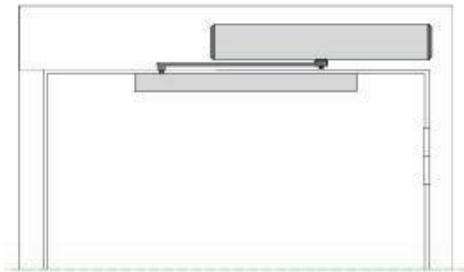

Push Arm

The door opens to the outside away from the unit using the push arm assembly.

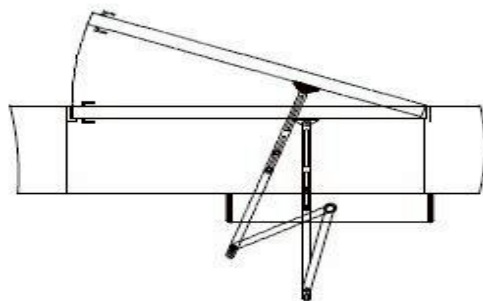
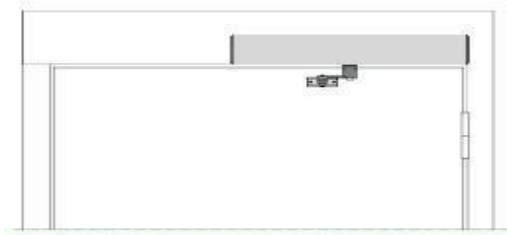

3 Installation

3.2 Installation of base plate

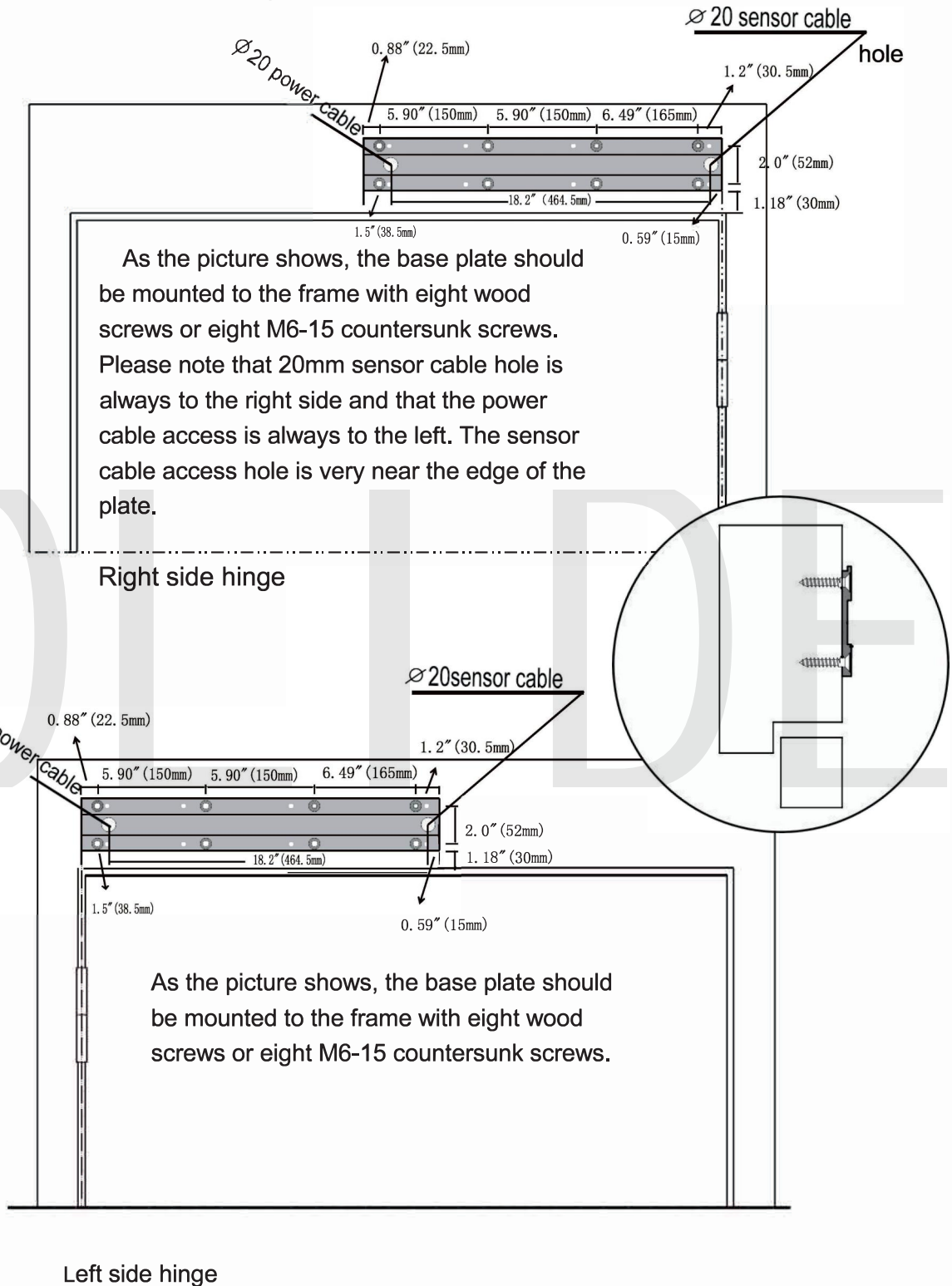

3 Installation

3.3 Installation of Pull arm

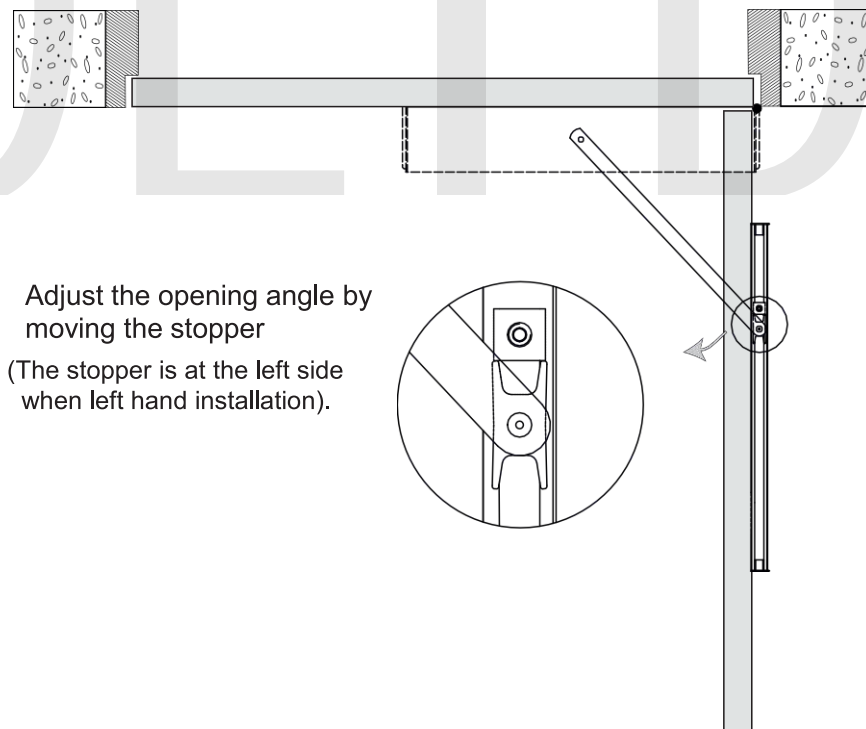
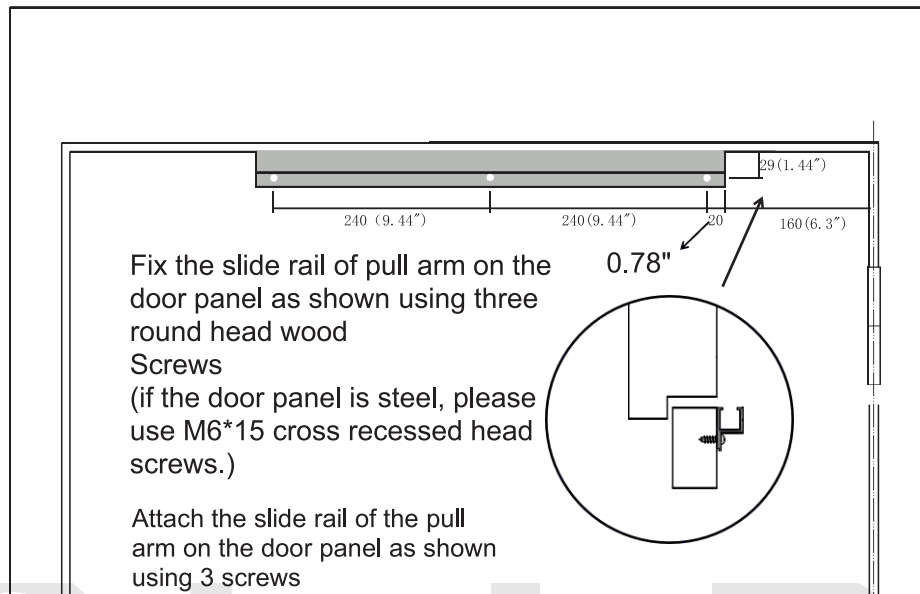

Right hand mount

3 Installation

3.4 Installation of Push arm

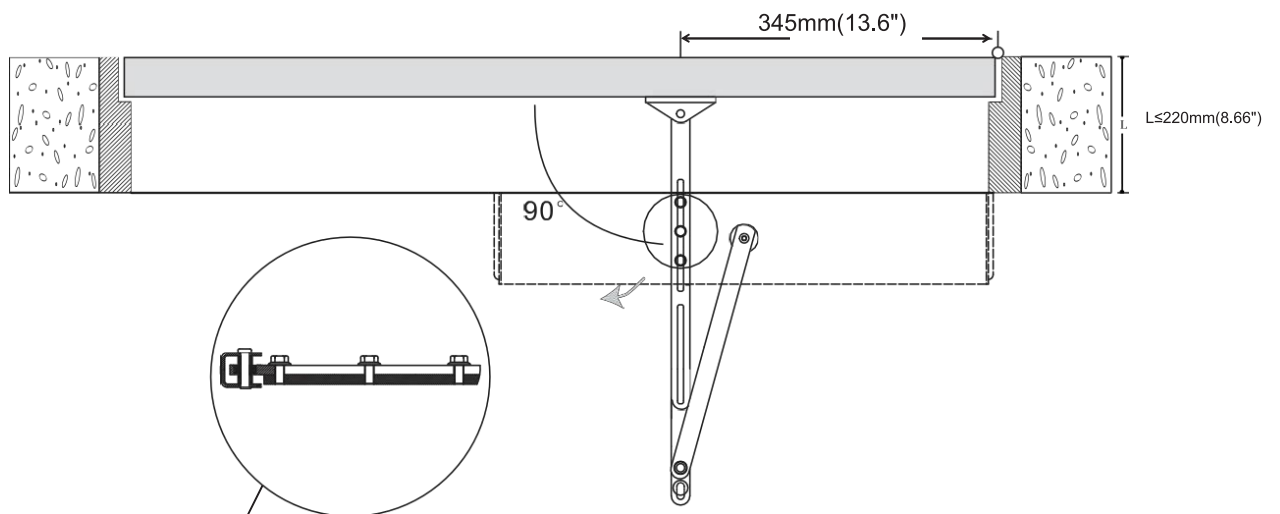
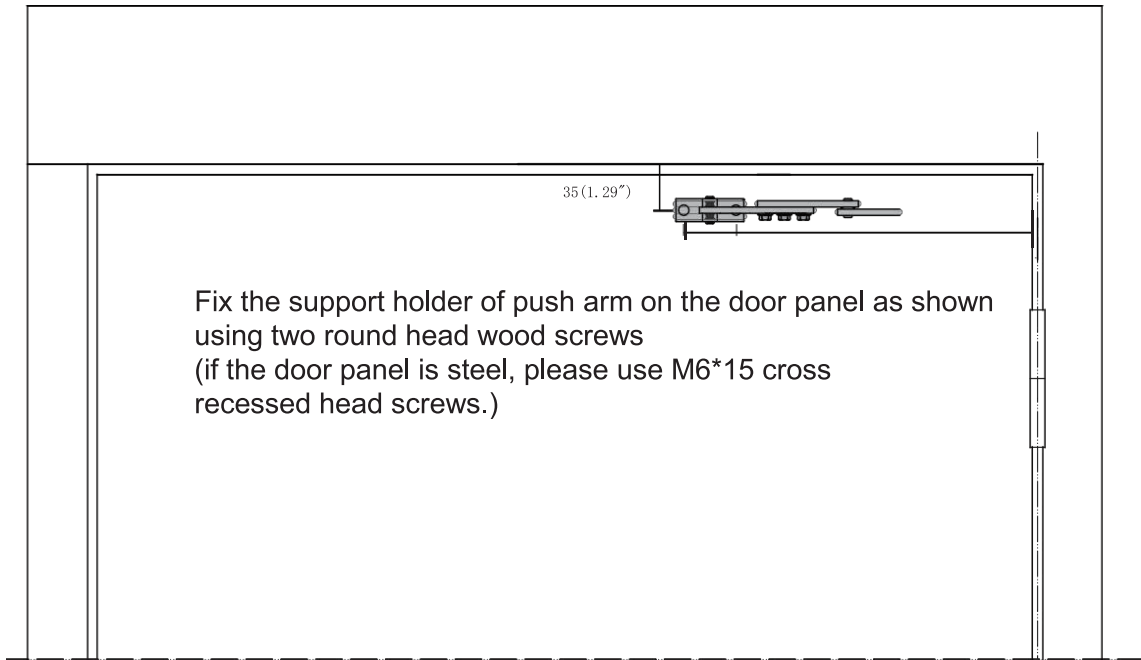

Loosen this 3 bolts and adjust the push arm length according to the door depth(L) until the angle between the push arm and the door panel is 90° .

Right hand mount

3 Installation

3.4 Installation of Push arm

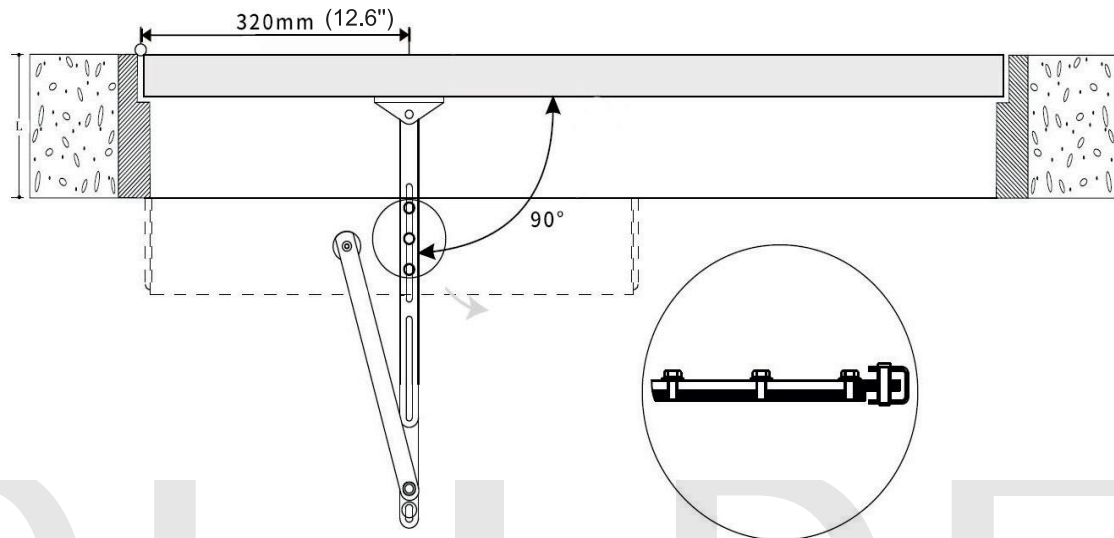

Loosen this 3 bolts and adjust the push arm length according to the door depth(L) until the angle between the push arm and the door panel is 90° .

Left hand mount

Stop screw

Adjust the stop screw position slotted hole to allow full opening of the door. Do not exceed 90° .

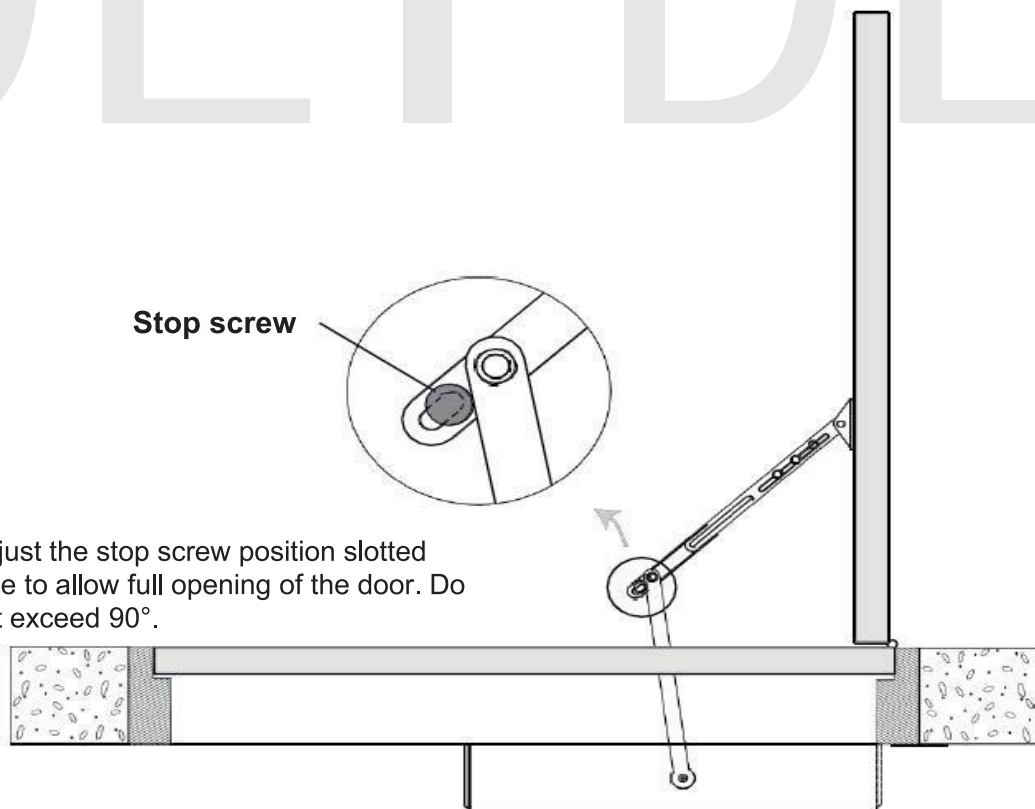

3 Installation

3.5 Installation of Push arm for frameless glass door

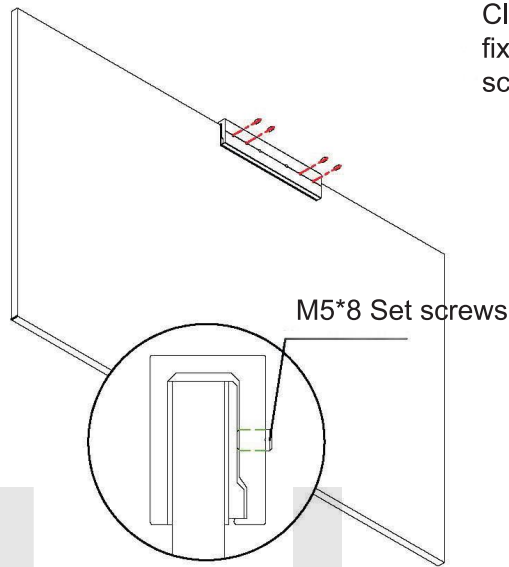

Clasp the door with door clamp tightly, then fix the clamp with M5*8 Hexagon socket set screws.

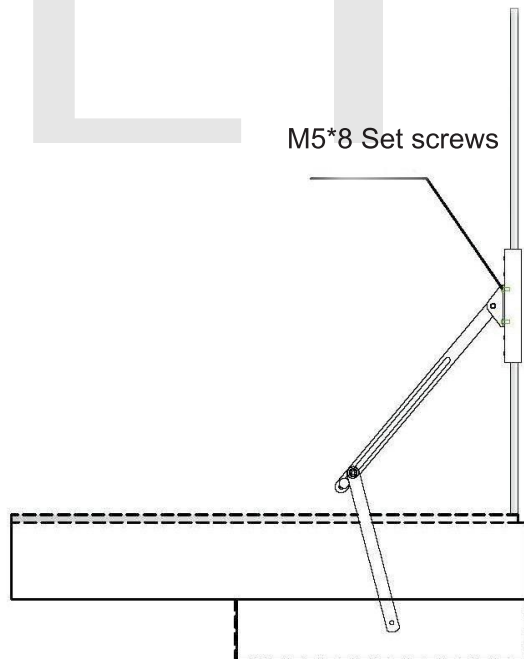

Please connect the push arm to the door clamp with the M5*8 Hexagon socket set screws. Then connect the push arm to the motor.

3 Installation

3.6 Installation of Pull arm for frameless glass door

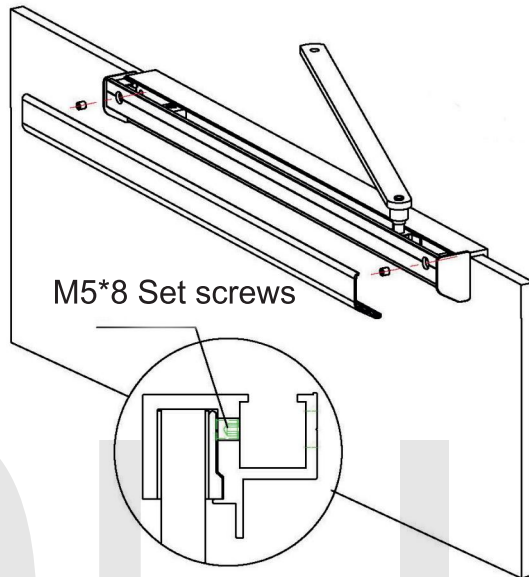

Clasp the door with door clamp tightly, then fix the clamp with M5*8 Hexagon socket set screws.

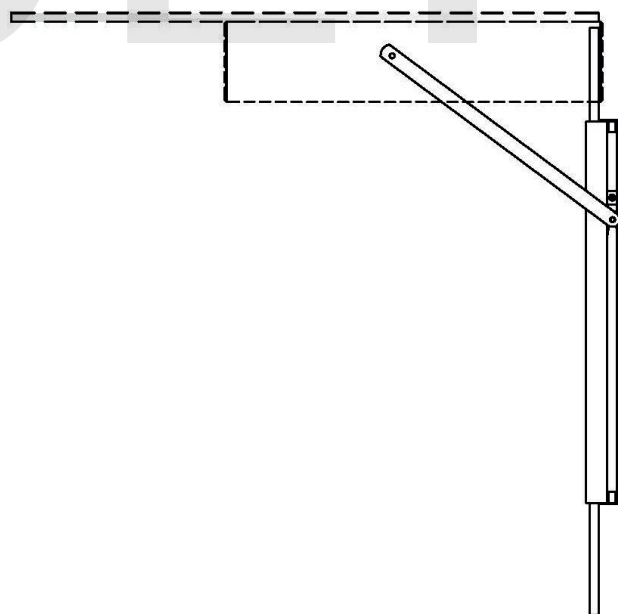

3 Installation

3.7 Installation of operation system

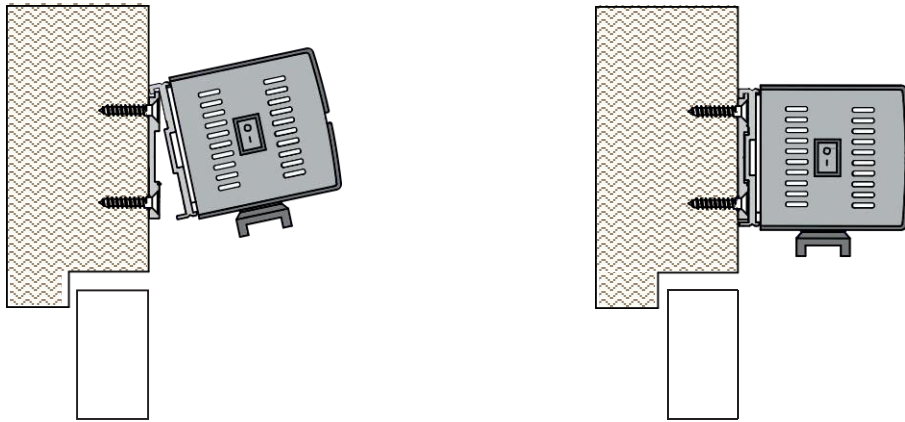

Hook the component assembly onto the base plate as shown.
Attach it with 8 allen head screws

3.8 Installation of Cover

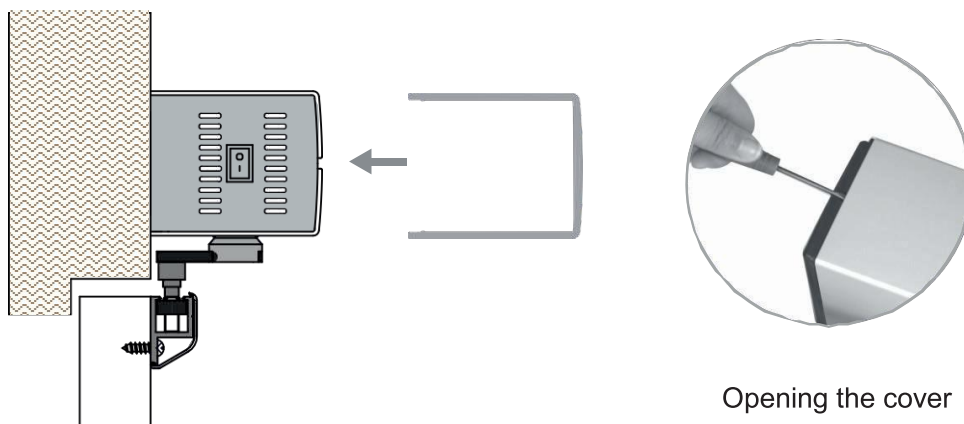

Opening the cover

3 Installation

3.9 Connect pull arm to the operation system

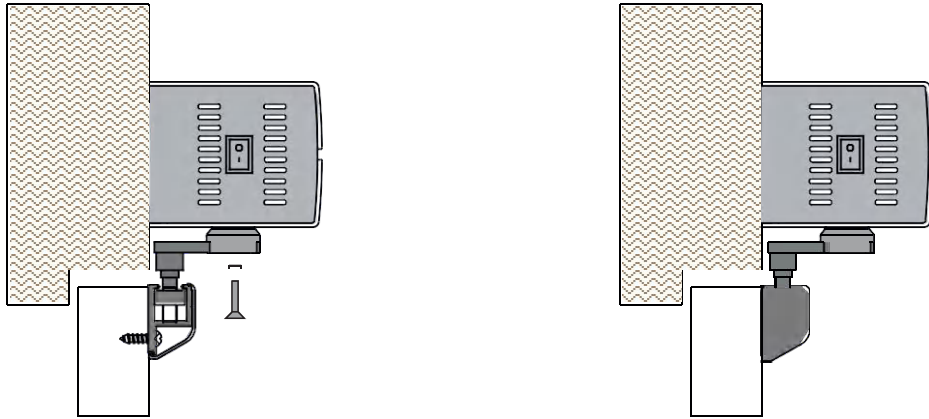

3.10 Connect the push arm to the operation system.

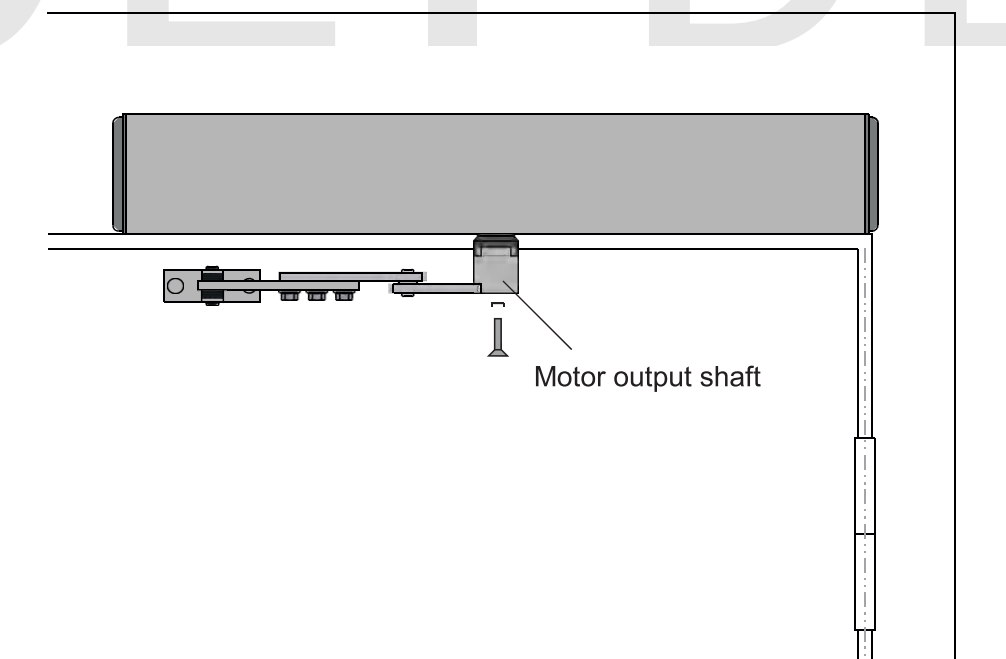

4. Electrical Connections

Control panel details

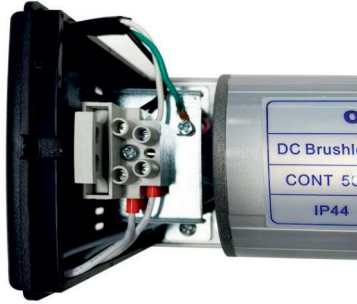

Power wiring:
Please connect the 110V-240V AC power input according the left picture.

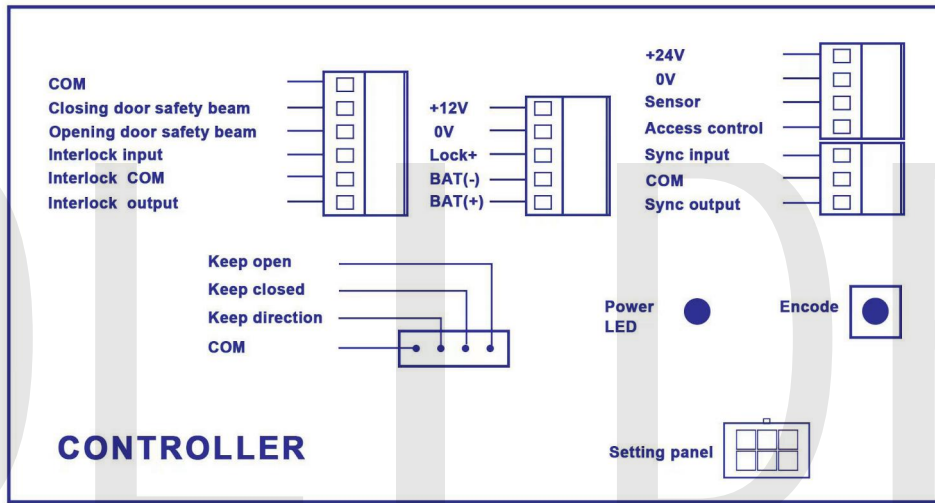

4.1 Connecting with access keypads

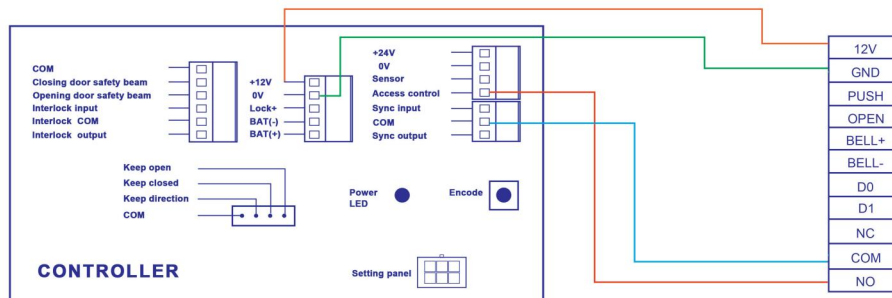

A07

4- Electrical Connections

4.2 Connecting to Smart Access Keypad 270,272

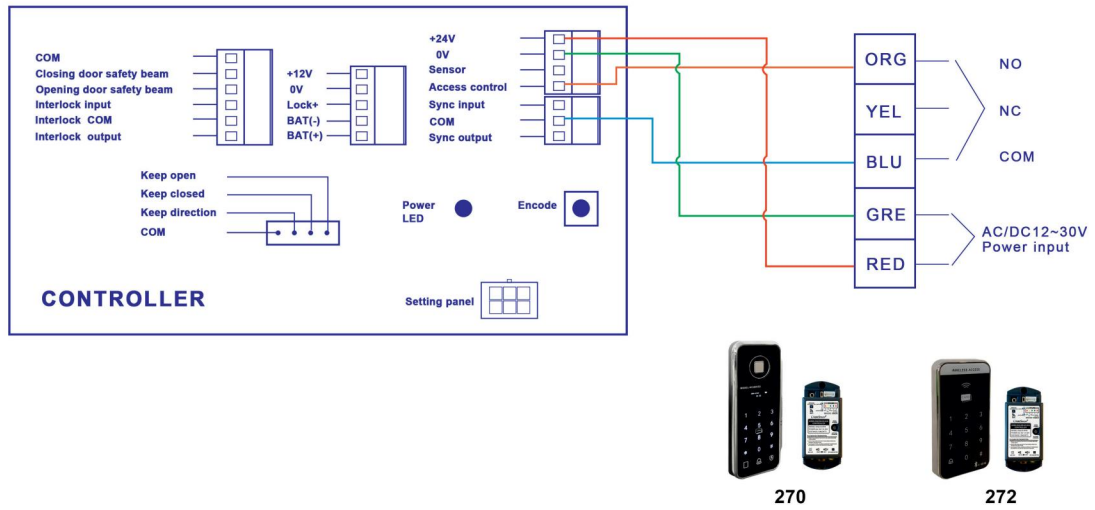

4.3 connecting to PIR sensors

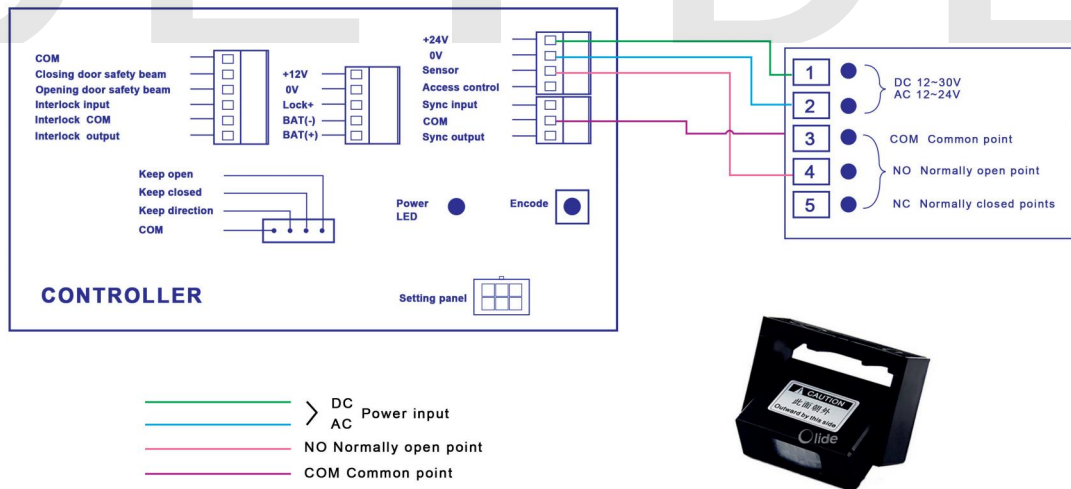

4- Electrical Connections

4.4 connecting to safety motion top scans

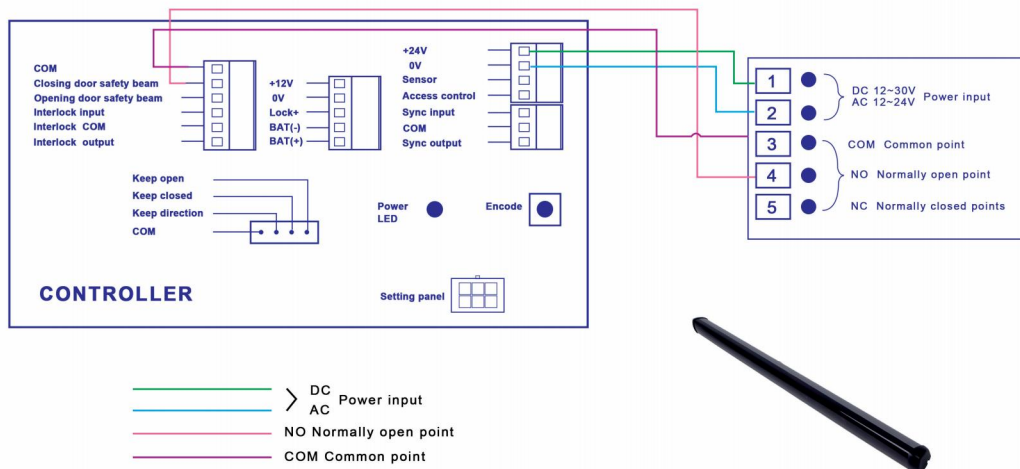

4.5 Connecting to plastic push buttons

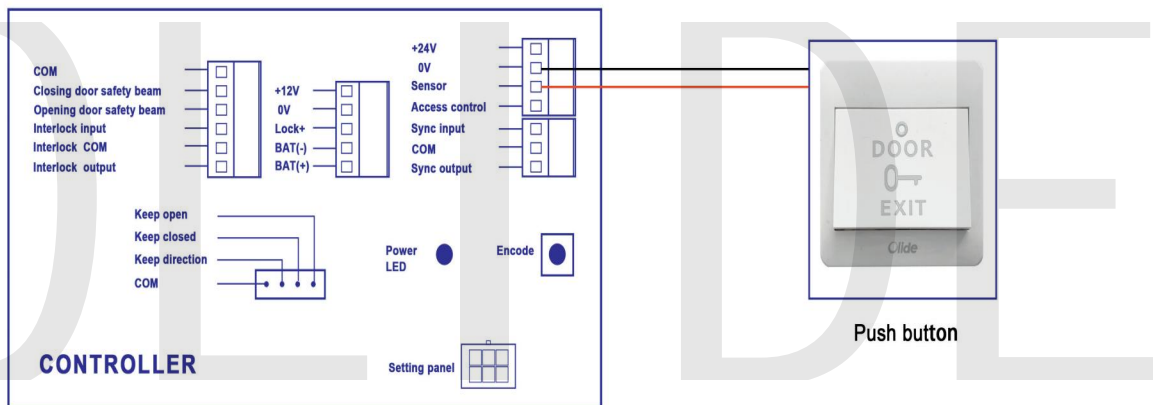

4.6 Connecting to wiring disabled push buttons

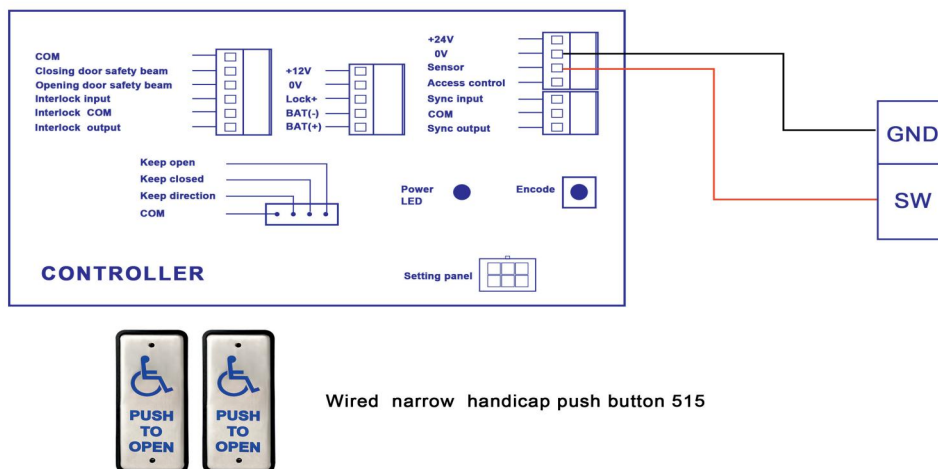

4- Electrical Connections

4.7 Connecting to wireless handicapped push buttons and wave to open switches

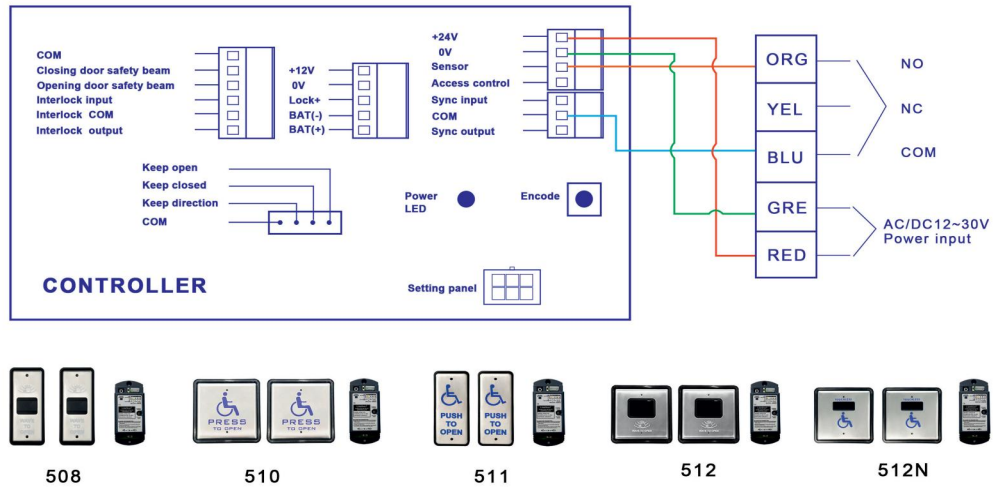

4.8 Connecting to magnetic locks

(Important Notes:As maglocks need constant power-You will need to press the LOCK button on the keychain remote control to initialize for it.It will work normally afterwards.)

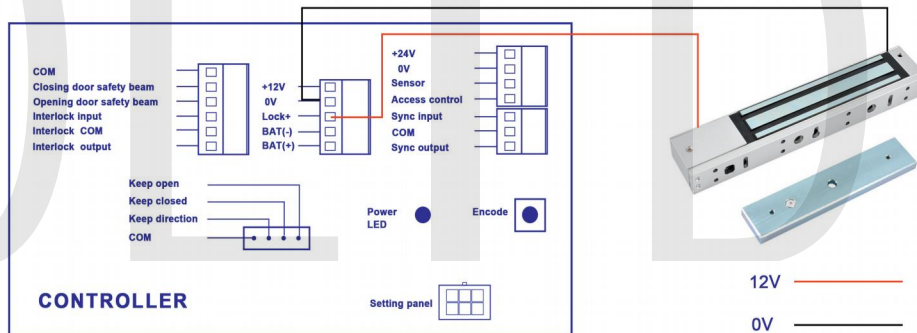

4.9 Connecting to electrical locks

(Important Notes:As maglocks need constant power-You will need to press the LOCK button on the keychain remote control to initialize for it.It will work normally afterwards.)

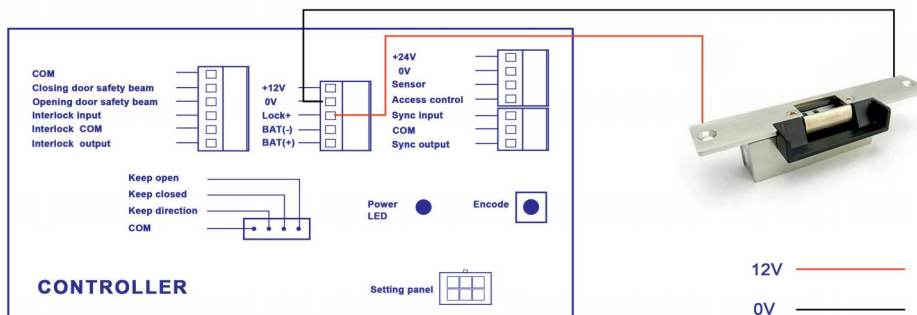

4 Electrical Connections

4.10 Connecting to hand sensor switches

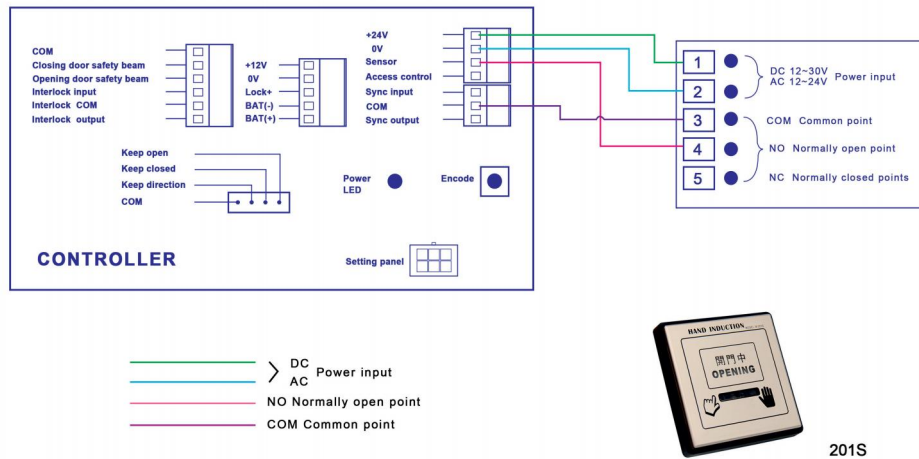

4.11 Connecting to wireless touchless sensor switch 25A

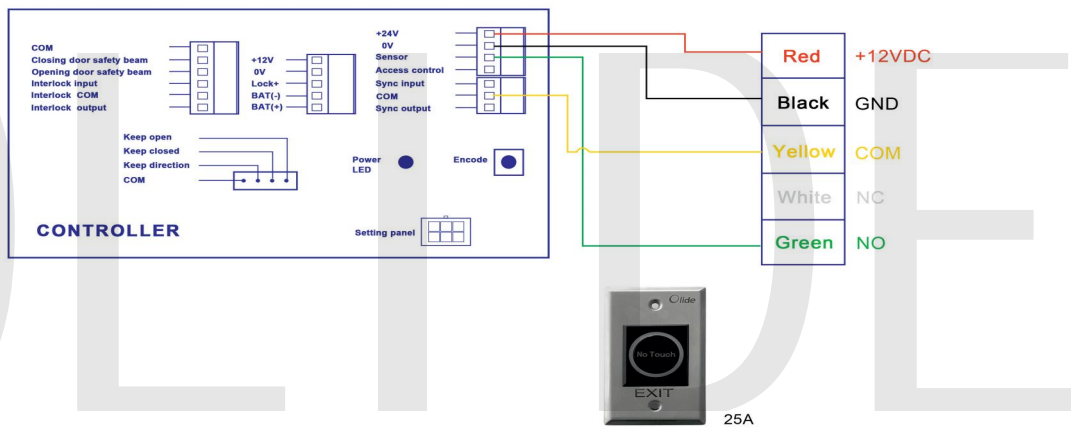

4.12 Connecting to wired touchless sensor switch 201G

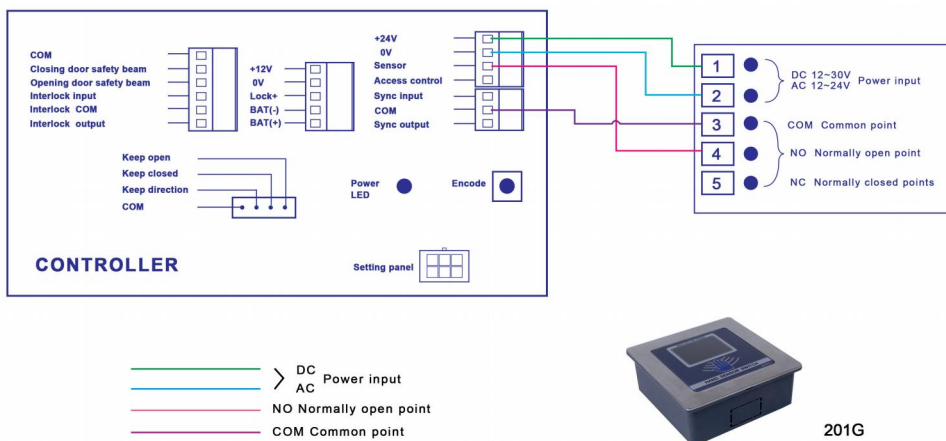

4 Electrical Connections

4.13 Connecting to wired touchless sensor switch DL56

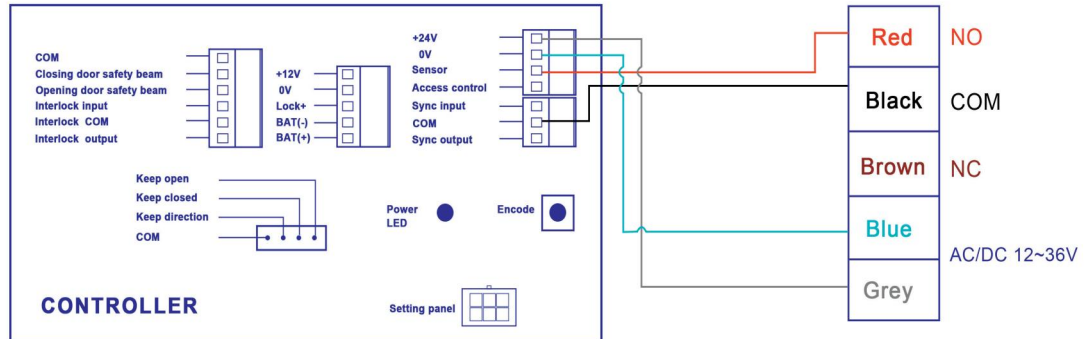

4.14 Connecting to wired handicap wave to open touchless buttons

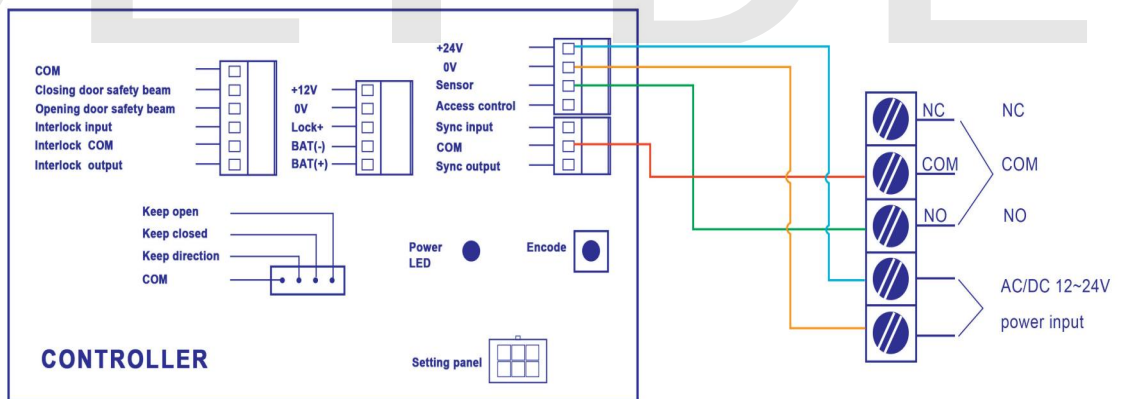

513



513N



514

4 Electrical Connections

4.15 Connecting to washroom switch for disabled

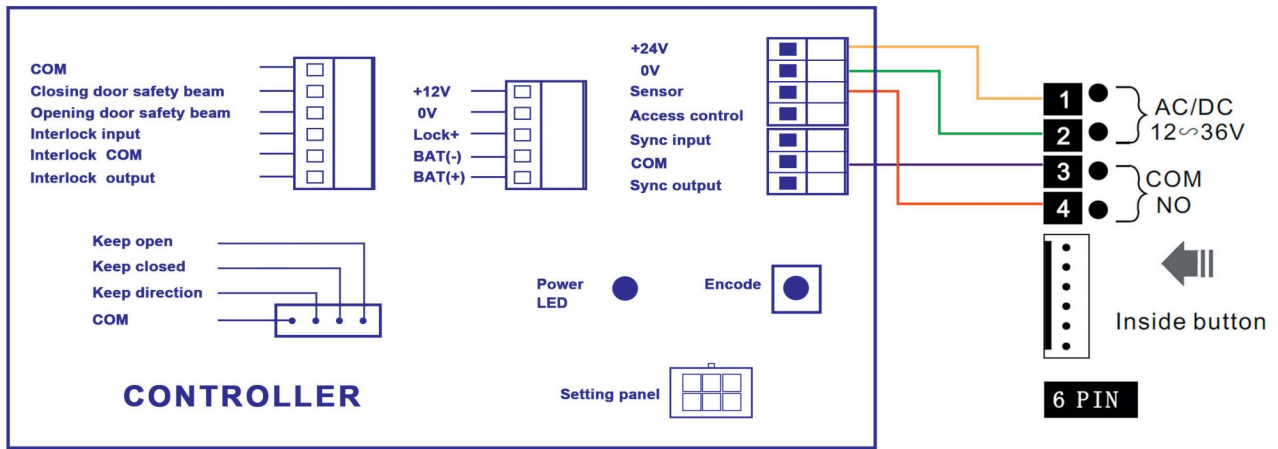

209

4.16 Connecting to wireless hand sensor switch 201W

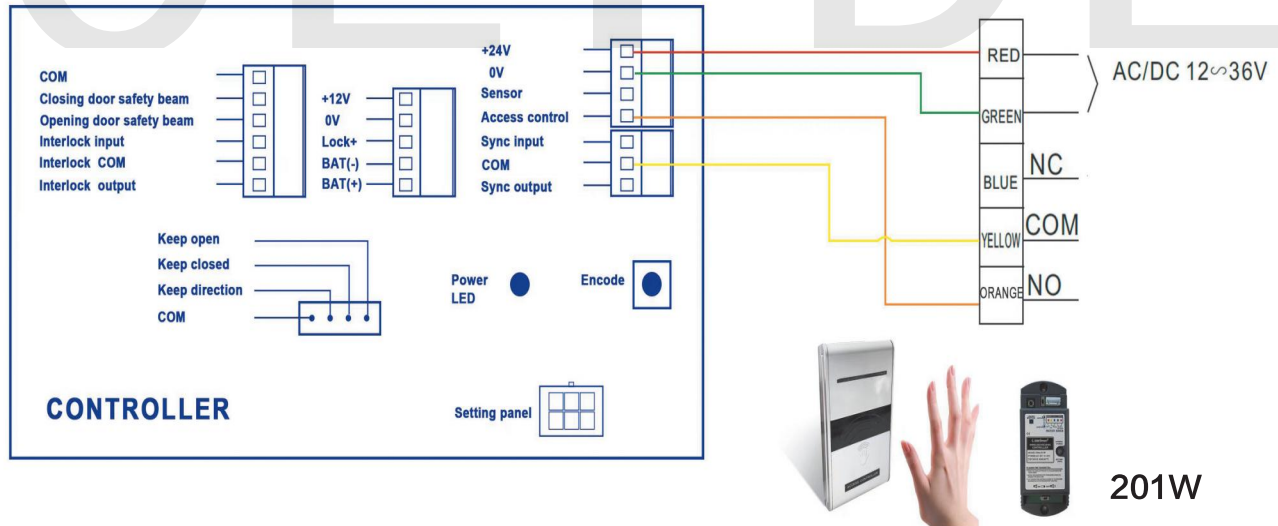

201W

4 Electrical Connections

4.17 Double door synchronous

connections **double door synchronous** :

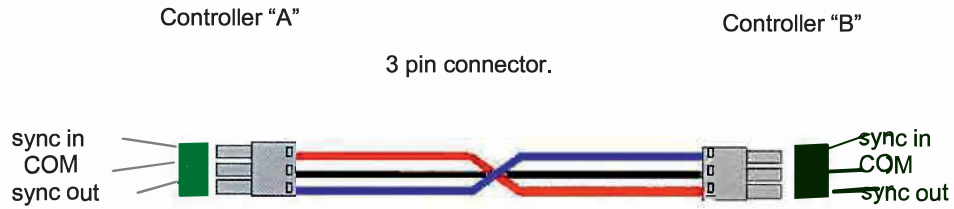

Interlock:

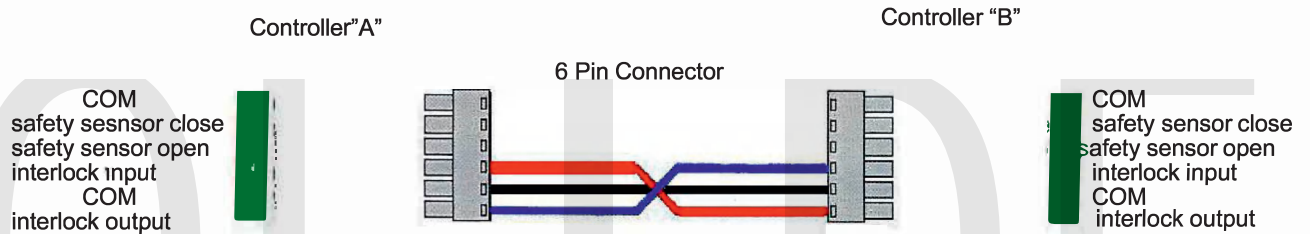

Please use the hand programmer for setting the double door synchronous . The detailed steps and are written on the Page 22 and 23.

4.18 Wireless push buttons settings

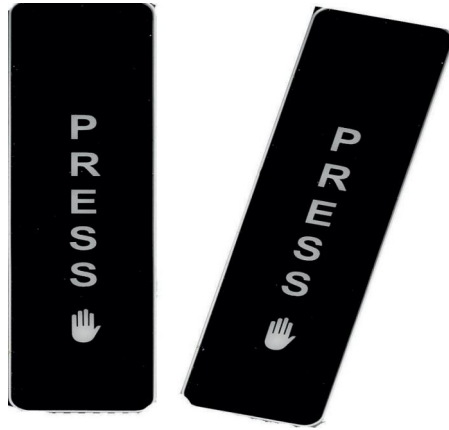

The wireless push button need to encoded with the door opener

Steps:

1. To delete: Press the "encode" button until the buzzer sound ceases, then release the "encode" button.
2. To pair: Press the "encode" button once-the buzzer will sound. Now press the "PRESS" button, the buzzer sound will cease, indicating that the code has successfully been learned. When you use the remote control, the buzzer will sound for 2 seconds.
3. Note: If you press the "PRESS" button, and if the buzzer sounds twice-this is indicating that the learning processes has failed, please repeat step 2 again.

4.19 Remote control settings

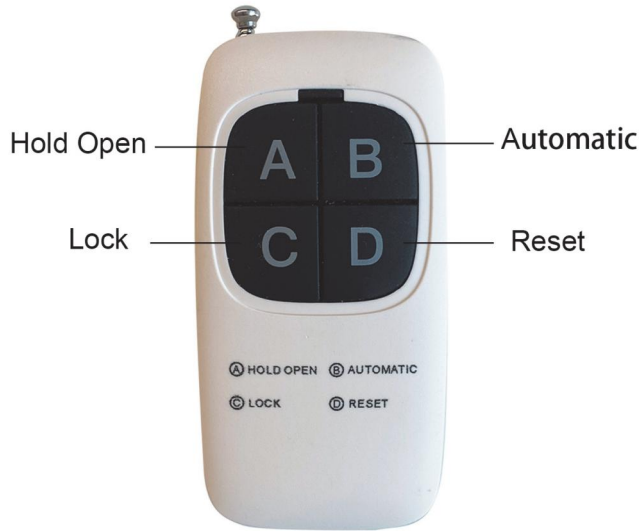

The remote control are pre-encoded to work with the door opener. Nevertheless, here is the process for encoding the remote with the opener.

1. To delete all codes: Hold the “Encode” button on the component assembly until the buzzer is silent.
2. To pair: Hold the “Encode” button until the buzzer sounds.
 - Then press any button on the remote control.
 - The buzzer should silence meaning that encoding process is complete.
3. If successful: when the remote control is used the buzzer will sound once, for 2 seconds. If the buzzer beeps twice, this means that the encoding has failed. Repeat step 2.
4. To open the door momentarily: Press the "Automatic" button once.

Note: A maximum of 30 keychain remotes can be used on any one operator.

Handheld remote control logical relationship with Signals

Signal \ Remote control	Sensor	Access control	E-lock(closed)
Hold-open	x	x	x
Lock	x	✓	✓
Reset	✓	✓	x

5 Parameters Adjustment

5.1 Hand programmer instruction

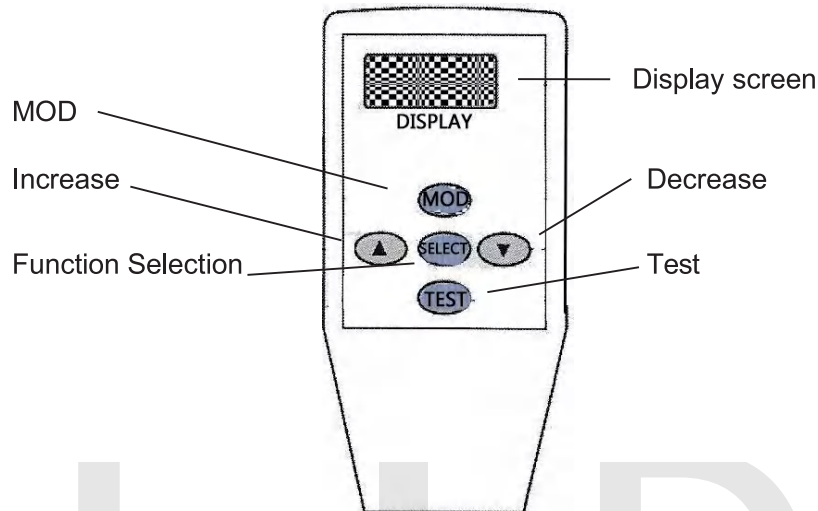

Display Screen guide and function display

F – 1 work parameters
os = opening speed
od = opening low speed angle
cs = closing speed
cd = closing low speed angle
jb = closing force
ot = opening hold time
ot= Hold opening time
LS=End closing speed
ERR3:Time out→Need to Replug
ERR4: Date Error→Need to Repair

F – 2 door parameters
n1 single/double door
n2 master/slave
n3 synchronize settings
o manual open door settings
L lock mode selection
F open direction settings
P door closer settings
C Locks setting
T Manually open in lock mode

increase operation = increase data
decrease operation = decrease data
function select / confirm parameter data

→ next parameter
→ parameters saved
→ parameters send

Important Note:

The Programmer may show " ERR3" when you just plug in. No worry, it is normal. As controller need a few seconds to recognize it. Then it will show"- - -", just press MOD to program.

5 Parameters Adjustment

5.2 adjustment steps

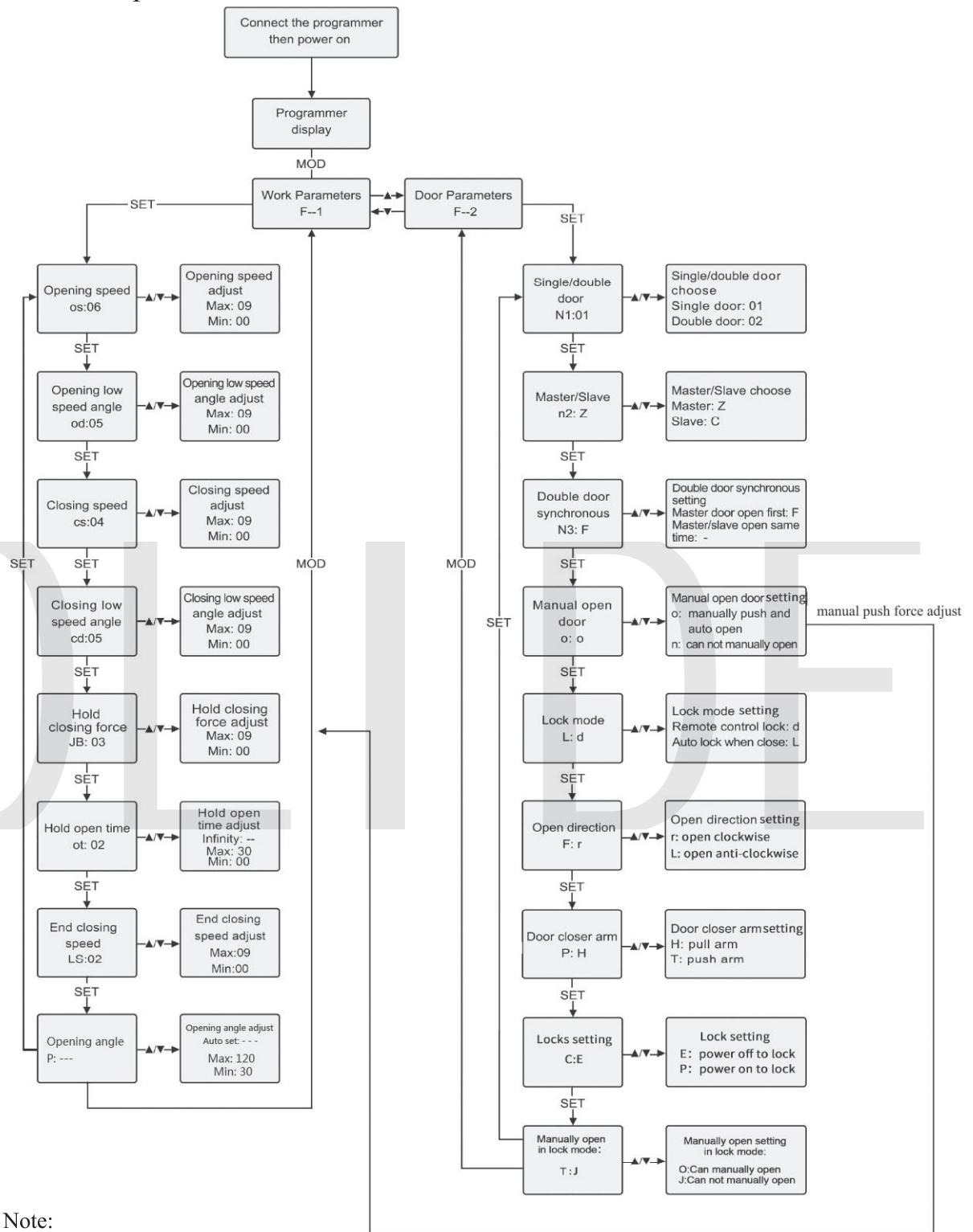

Note:

- ① If you want to adjust the manual push force for push&go function, just adjust Hold closing force "JB" accordingly.
- ② If you want to add bigger closing force, please adjust the higher end closing speed "LS"
- ③ If you want press button once for open, and press again for close, please adjust the hold open time "ot: to "- -"
- ④ The default setting for manually open function is deactivated in locking mode, So need to set F-2, t with O: Can manually open

6 Trouble shooting

(Please email us if problem still can not be solved, tech@olideautodoor.com)

Symptoms	Remedies
The door stay open not auto close (Open directin is wrong)	Turn the power off, manually open the door halfway. Turn the power back on,check to see the door closes in the correct direction.If not change the opening direction using the Handheld Programmer.
The opener keep turning,not stop	It is normal if not be installed, as it can not find a closing position.
The opener still keep turning even fully closed.	Push arm install size is not correct, need to add the push arm install size which away from the door hinge.
The door rebounds when closing, and repeats opening and closing.	Check for obstacles – clear if necessary. Increase the closing force with the hand programmer. Push arm install size is not correct, need to add the push arm install size which away from the door hinge.
Lock doesn't work.	Ensure you have pressed the lock button on handheld remote (Initial use only) Ensure lock setting on auto door is correct. (Power on to lock or Power off to lock.)
Can not fully closed	Add the end closing speed by handheld programmer.
Difficult to manually push open	Reduce Hold closing force by handheld programmer.
Remote or wirless push button not work	Check if have battery Did not learn the code, need to encoding the code.
Wireless push button (receiver built in the opener) not work or only sometimes work	The Wall block the receiver wireless signal, need to pull out the receiver's antenna. (Need to open the door opener controller's cover)